

Bienesol

BALCONY ALL-IN-ONE ESS CUBE SERIES



Cube-AIO-M/
Cube 2700-E

Contents

Introduction	3
Symbols Used in This Guide	4
System Introduction	4
Product description	4
Unboxing Guide	5
Product Dimension	6
Electrical Function	7
LED Display	9
Installation	9
Heavy Object Handling Safety	9
Assembly Process	10
Power On	12
Monitoring System	12
Operating Mode	15
Fault Codes and Trouble Shooting	18
Technical Parameters	23
Maintenance Guide	25
Routine Maintenance	25
Energy Storage Unit Maintenance	25
Storage and Disposal	26
Warranty	26
Dealer Responsibilities	27

Introduction

Thank you for choosing BIENESOL products. We hope our products can meet your needs for renewable energy. We also appreciate your feedback on our products.

Safety Introduction

Disclaimer:

Read all safety guidelines, warnings and other product information in this manual carefully, and read any labels or stickers attached to the product before using. Users take full responsibility for the safe usage and operation of this product. Familiarize yourself with relevance regulations in your area. You are solely responsible for being aware of all relevance regulations and using BIENESOL products in a way that is compliant.

Keep this manual for future reference.

This equipment should be used in an environment that complies with the design specification. Failure to do so may result in equipment failure, malfunction or component damage, personal safety accidents, property losses, etc., which are not covered by the equipment quality assurance.

Our company does not assume any responsibility for the following situations:





- Operation not within the specified operating conditions in this manuals.
- Installation and use environments outside the limits of relevant international or national standards.
- Unauthorized disassembly or modification of the product software code.
- Failure to follow the operating instructions and safety warnings in the product manual.
- Damage to the device caused by abnormal natural conditions (force majeure, such as earthquakes, fires, storms, etc.).
- Transport damage caused by the customer.
- Damage caused by storage conditions that do not meet product requirements.

Dangers:

- In the event of a fire, evacuate the building or equipment area and press the fire alarm or call the fire department. Reentering a burning building is strictly prohibited under any circumstances.
- Do not disassemble or modify the energy storage unit without permission.

Symbols Used in This Guide

Thank you for choosing BIENESOL products. We hope our products can meet your needs for renewable energy. We also appreciate your feedback on our products.

Symbol	Explanation
	Comply with EU Declaration of Conformity
RoHS	Comply with RoHS directive
	Read this manual before installation, operation and maintenance
	Must not be disposed of as household waste
	This symbol indicates the presence of high voltage and risk of electric shock
	To avoid electric shock or injury, do not touch or use the inverter at least 3 minutes after turning it off or disconnecting it from other power grids

System Introduction

Product Description

This user manual describes the energy storage system performance specification, operating conditions and warning information. It applies only to this product.





The energy storage system consists of a photovoltaic hybrid inverter, battery packs and a wireless communication module. When connected to solar panels, it forms a photovoltaic power generation and battery energy storage system. Its primary function is to convert DC power from photovoltaic into AC power and output this power to the load or grid. This system is equipped with an energy management system (EMS) and a battery management system (BMS) to monitor data, provide early warnings and control of the battery units. This system can be used for both off-grid and grid-connected hybrid solar systems, suitable for home and balcony applications.

This system must be used in conjunction with BIENESOL Cube 2700-E energy storage battery pack.

Unboxing Guide

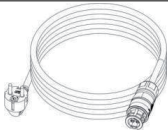
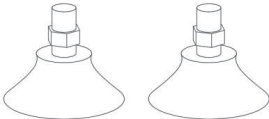
What's in the box

Before unpacking the box, check the outer packaging for damage, such as holes and cracks, and check the equipment model. If you find any damage or the model dose not match your order, do not unpack and contact BIENESOL customer service.

		
PV hybrid inverter	AC End Cable (2meters) × 1	Base × 4
		
Dust Plug × 1	PV Disassembly wrench × 1	User Manual × 1

Optional accessories

The following accessories must be purchased separately.

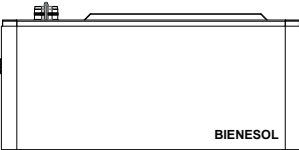
BIENESOL Master Meter	BIENESOL Cube 2700-E
	

Product dimension

• Inverter dimension

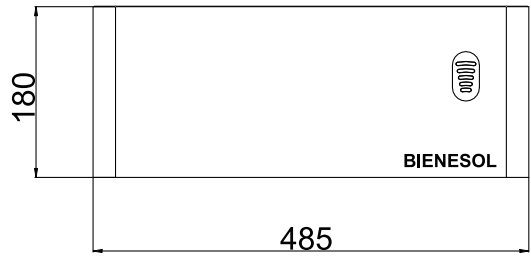
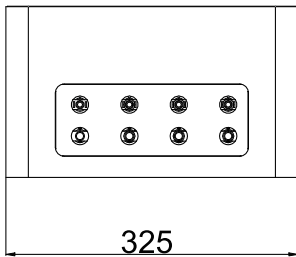

• Battery pack dimensions

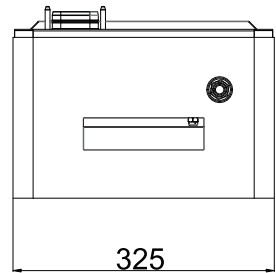
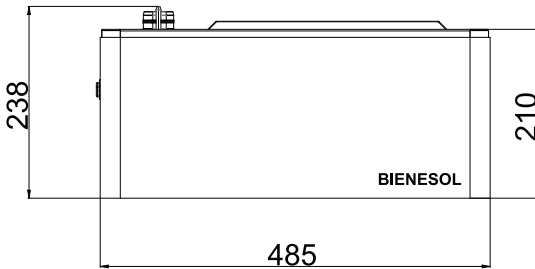

• system dimensions

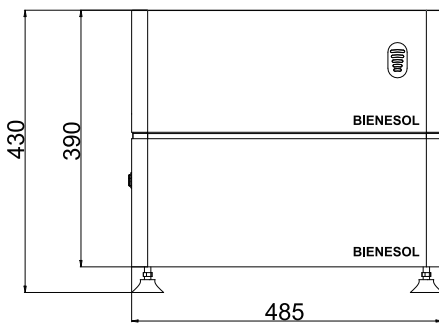

2662Wh

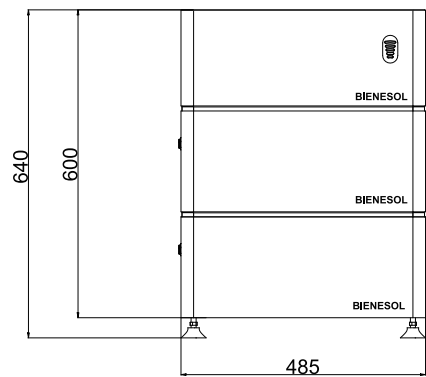

5324Wh

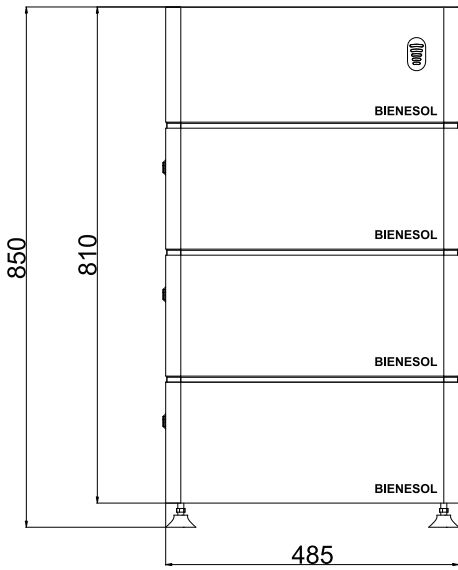

7986Wh

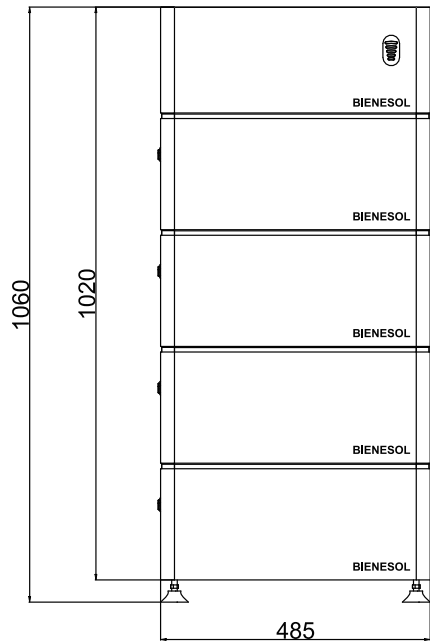

10648Wh

Electric Function

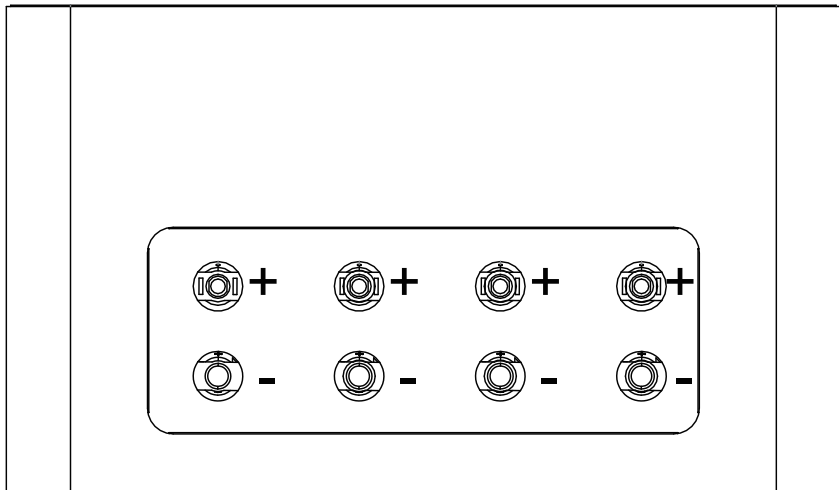

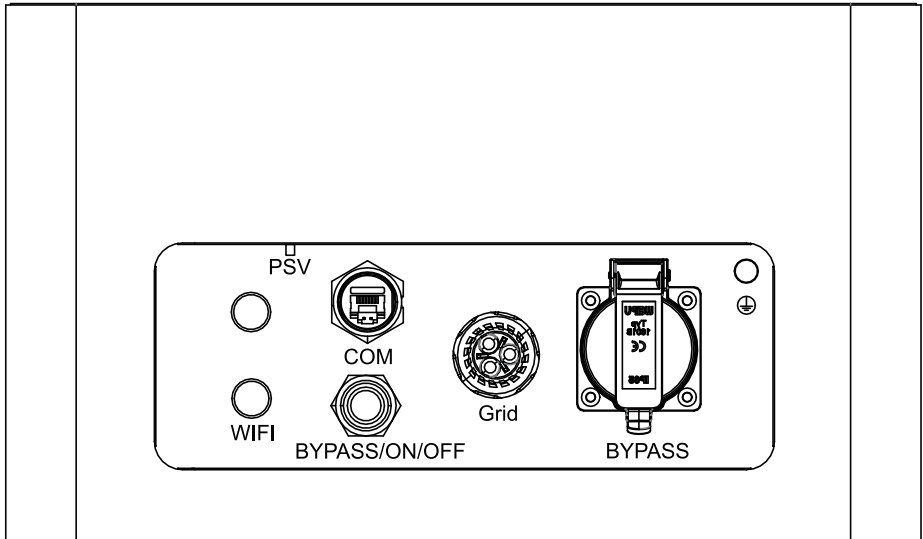

Name	Description
WIFI	Inverter and wireless meter communication antenna
COM	Inverter host computer communication com port
BYPASS/ON/OFF	Inverter BYPASS switch button, short press for 1 second to turn on BYPASS, short press for 2 seconds to turn off BYPASS (when the indicator light is in sleep mode, short press for 1 second to activate the indicator light)
PSV	Inverter vent valve
Grid	Inverter AC grid-connected interface
BYPASS	Inverter off-grid load port
+	Photovoltaic input positive port
-	Photovoltaic input negative port
⏚	Inverter external grounding

LED Display

LED Description	Detailed Explanation
Blinking Green Light	Network disconnected
Solid Green Light	The network connection is normal and the device is operating normally.
Blinking Red Light	System failure alarm
White LED lights cycle	Battery charging normally
Solid White Light	Display current battery level
All LED light cycle	OTA is updating

Note: When the device is operating normally and there is no operation, the indicator light will enter the sleeping state after 5 minutes. Press the BYPASS button to reactivate the indicator light.

Installation

Choose a location for the inverter:

- Avoid electromagnetic interference that may affect the normal operation of electronic equipment;
- Do not install in direct sunlight, near fire sources, or near explosive materials;
- Ensure the installation location is free of potential risks (such as flooding);
- The installation altitude must not exceed 2000 meters;

Measure the installation distance and allow sufficient space for heat dissipation and safe insulation.

Heavy Object Handling Safety

- When moving the energy storage system pack, be prepared to bear the weight and avoid being crushed or sprained.
- When moving the pack after work, it is recommended that two people lift it together and wear protective gloves to prevent injury.

Assembly Process

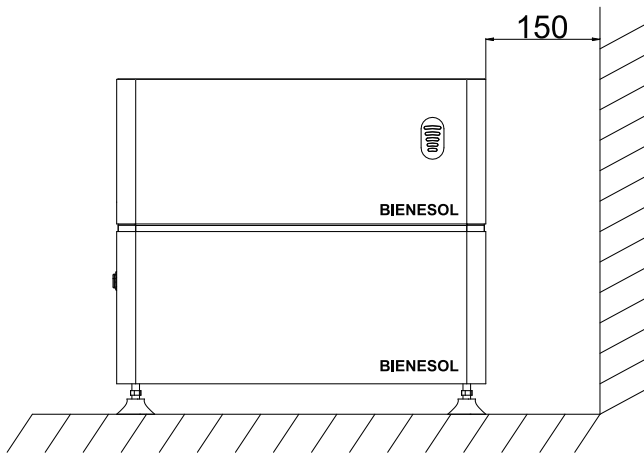
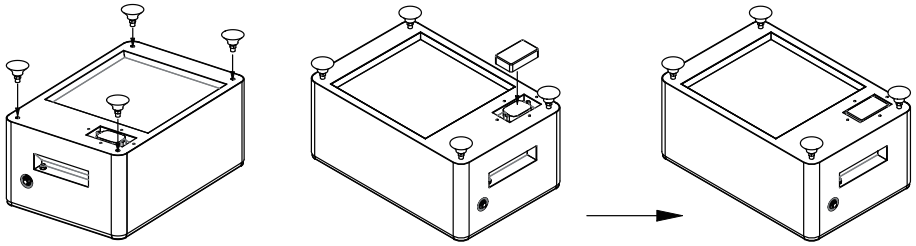

Step 2: Install PV hybrid inverter on the battery pack, with the top ≥ 150 mm away from the wall.

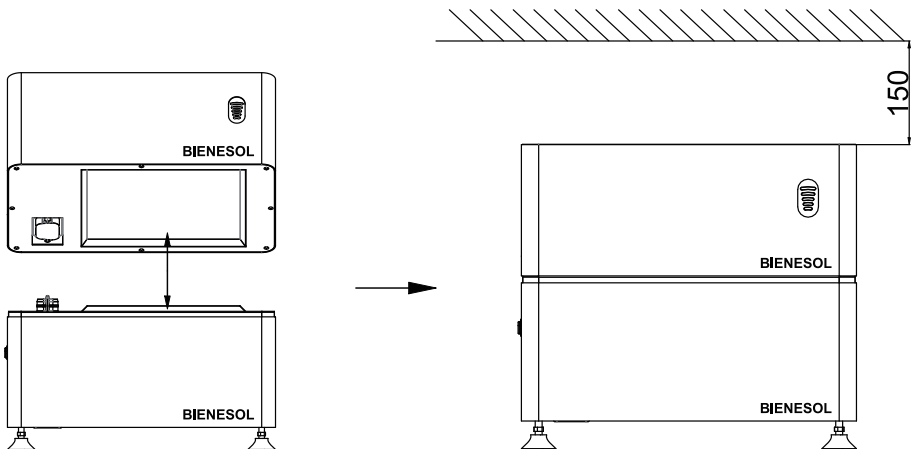

Step 3: Use an M8*10 screw to connect the PE grounding wire to the grounding wire installation hole of the inverter.

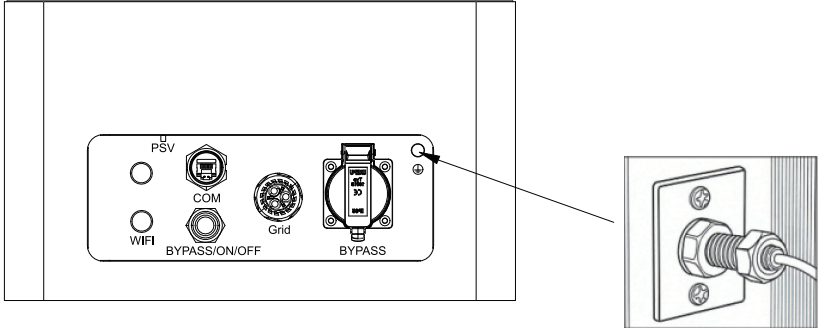

Step 4: Install the solar panels into the photovoltaic input port, connect it to the Grid terminal using an AC cable, and then connect it to the grid. If necessary, connect your home devices to the BYPASS terminal. (A single photovoltaic input voltage exceeding 60V or a current exceeding 16A will damage the device.)

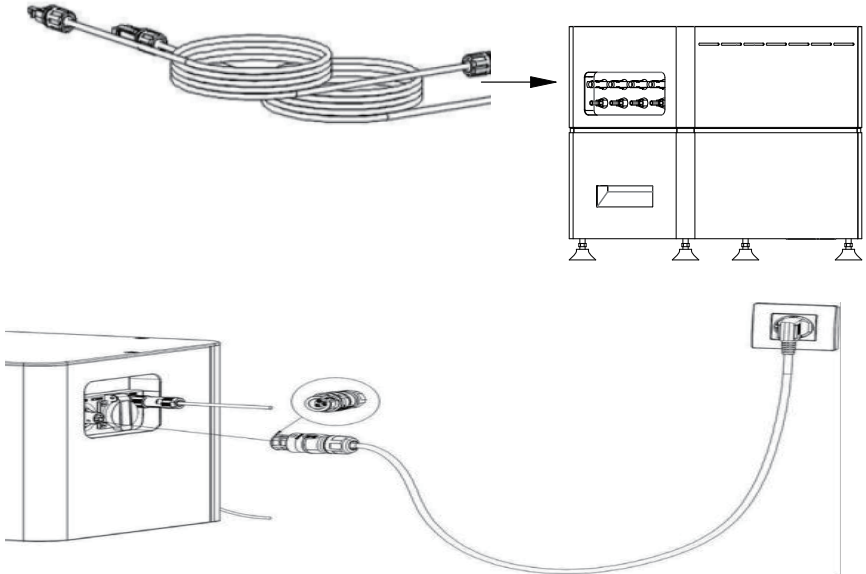

Note: If only one layer of battery pack or one solar panels is installed, be sure to install the dust plug in place to prevent water from entering.

Power On

After completing the installation, press the power button. The button indicator light will turn green and the equipment will enter the operating state.

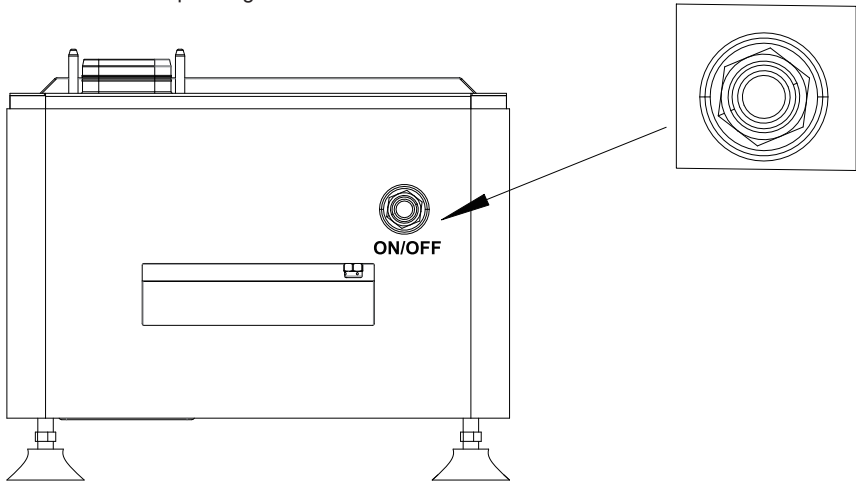

When shutting down the equipment, you need to use a photovoltaic disassembly tool to disconnect the photovoltaic connection, disconnect the AC cable, and then turn off the power of the energy storage system.

Monitoring System

Step 1: Download APP

- IOS users: You can search "wei sheng Cloud" directly in the Apple APP Store, download and install the software.
- Android users: You can search "wei sheng Cloud" in Google Play directly, download and install the software.
- Scan below QR code, download and install the software.

Scan the QR code to download the APP



iOS



Android

Step 2: Register and log in

Click “Register”, fill in the registration information, and read the “User Agreement” and “Privacy Policy”. After completing the registration, log in to your account to use the APP.

The image displays two screenshots of the WeiSheng Cloud app interface during the registration process.

Left Screenshot (Login/Registration Screen):

- Time: 13:10
- Language: English
- Logo: WeiSheng Cloud
- Section: **Welcome WeiSheng Cloud**
- Form: Username/Email (demo@abc.com)
- Form: Password (Password)
- Checkbox: I have read and agree to the User Agreement and Privacy Policy.
- Buttons: Login, Forgot Password?, Register (highlighted in red)

Right Screenshot (Registration Form):

- Time: 13:10
- Section: **Register**
- Text: Register for an account to access the full features of the app
- Form: E-mail (demo@abc.com)
- Form: Security Code (039400) with Send button
- Form: Username (abc)
- Form: Password (*****)
- Form: Timezone ((+08:00) Asia/Shanghai)
- Section: **Installer Information** (dropdown)
- Checkbox: I have read and agree to the User Agreement and Privacy Policy.
- Button: Register

Step 3:

Click “Create Power Plant”, fill in the power plant information, select “HESS” as the Business Type, and complete the power plant creation.

The image shows the "Business Type" selection screen in the app.

- Section: **Business Type**
- Option 1: **PVS** (Photovoltaic systems are ideal for monitoring grid-connected inverters, micro-inverters, and optimizers)
- Option 2: **BESS** (Battery system for single high and low voltage battery systems and other equipment monitoring scenarios)
- Option 3: **HESS** (Household energy storage is ideal for monitoring hybrid inverters, storage inverters, and home energy management systems) - **Selected**
- Option 4: **EMS** (Commercial energy storage is ideal for monitoring small and medium-sized standard commercial and industrial energy storage systems)

Step 4:

Click the “≡” icon in the upper right corner of the software, select “ Add Logger” and scan the QR code on the PV hybrid inverter in the lower right corner.

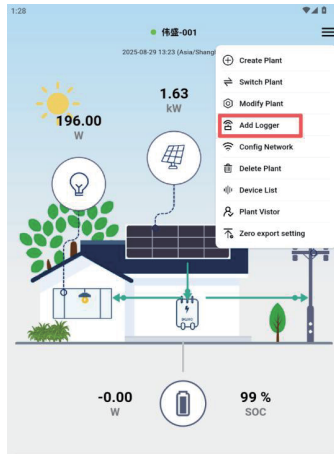

Step 5:

Click “ Config Network”, select the networking-configurable device and check it, select the wireless network and enter the wireless network password, click Save, and wait fo about 60 seconds. The device will be successfully configured with the net work.

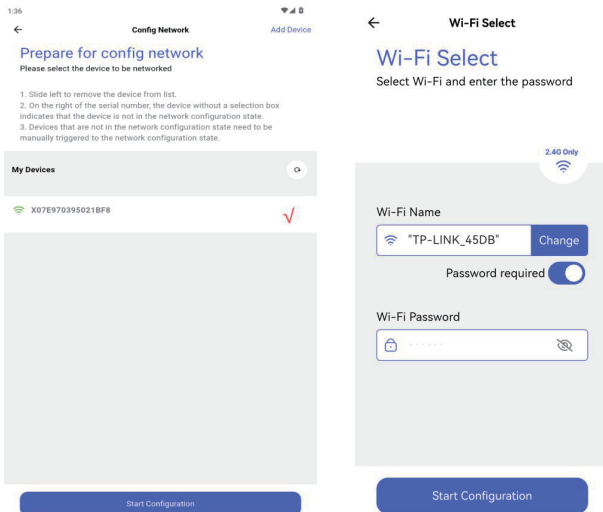

Note: Network configuration requires Wi-Fi in the 2.4GHz band. If an error message appears, please check the following possible causes and try again.

- Confirm that the Wi-Fi password is correct and that the Wi-Fi name contains no special characters (only numbers and letters are supported).
- Confirm that the Wi-Fi and router are operating only on the 2.4GHz band (the device does not support the 5GHz band).
- The Wi-Fi signal strength displayed on your phone should be at least 2 bars.
- A router can connect to up to 9 devices (including the PV hybrid inverter, mobile phone, computer, etc.)
- Ensure that the WLAN (wireless local area network) and Bluetooth functions on your phone are enabled.
- Try reducing the distance between your phone and the device. After approximately 60 seconds, the Wi-Fi configuration will be completed, and the PV hybrid inverter system data will be transferred to the server.

Operating Mode

There are 4 operating model in the PV Hybrid inverter system: self-generation and self-use mode, backup power supply mode, program control mode and planned mode.

Operating mode: Self-generation and self-use

Priority: Load > Battery > Grid

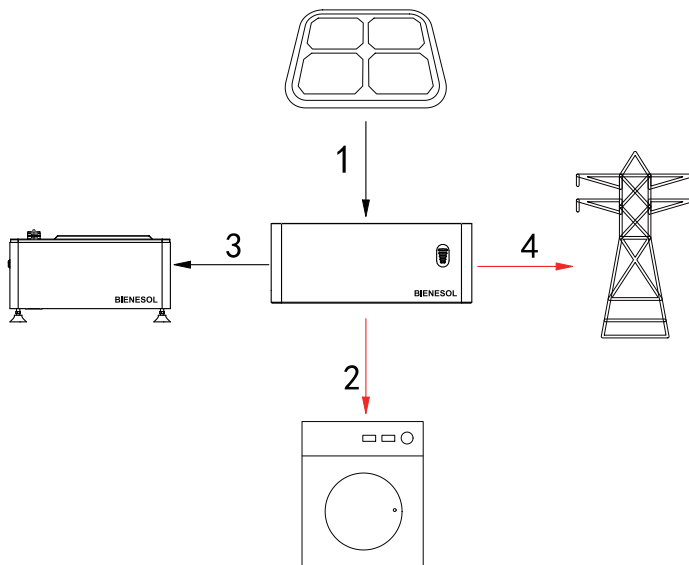

In this mode, PV self-use has the highest priority, and excess PV power takes precedence over supplying BYPASS loads, charging batteries, and then feeding back to the grid.

Operating mode: Backup power supply

Priority: Battery > Load > Grid

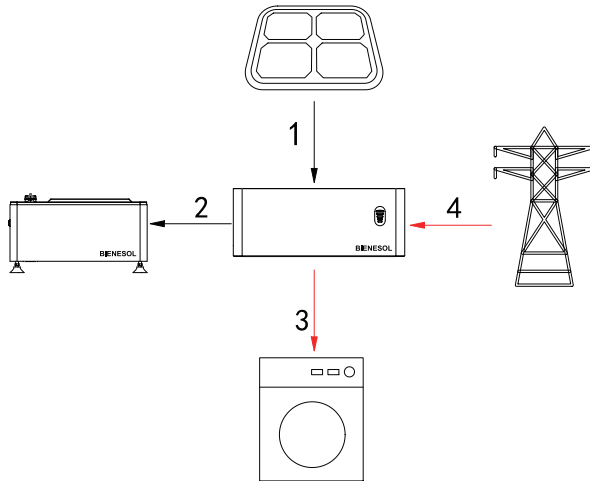

In this model, photovoltaic power supplies BYPASS loads first, and excess power is used to charge the battery. Charging stops when the battery reaches full charge SOC, and excess photovoltaic power is fed into the grid.

Operating mode: Program control (Charging)

Priority: Battery > Load > Grid

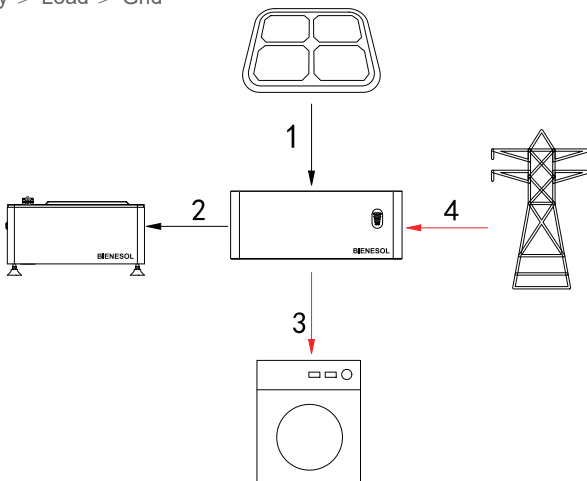

Operating Mode: Program control (discharging)

Priority: Load > Battery > Grid

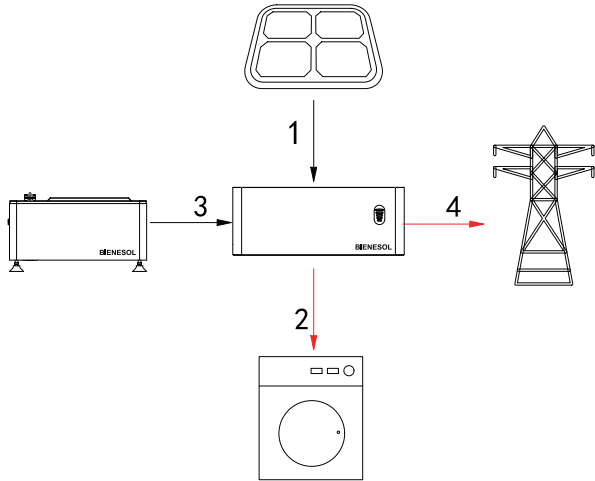

In this mode, users can schedule the inverter in real-time via Wi-Fi or the RS485 communication port, switching between charging and discharging states.

Charging: When grid power is available, the photovoltaic and grid power prioritize charging the battery at the configured power level. When the battery reaches the set SOC, charging stops and the photovoltaic power is discharged to the grid.

Discharging: Photovoltaic and battery inverter power prioritizes off-grid loads, with any excess power discharged to the grid (total power not exceeding the rated power).

Operating Mode: Planned mode (charging)

Priority: Battery > Load > Grid

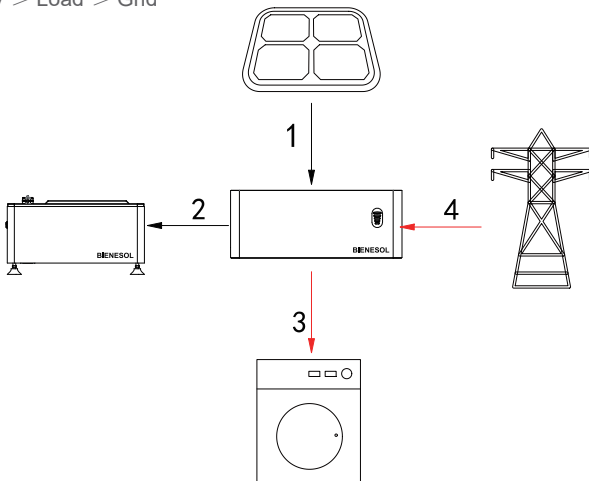

Operating Mode: Planned mode (discharging)

Priority: Load > Battery > Grid

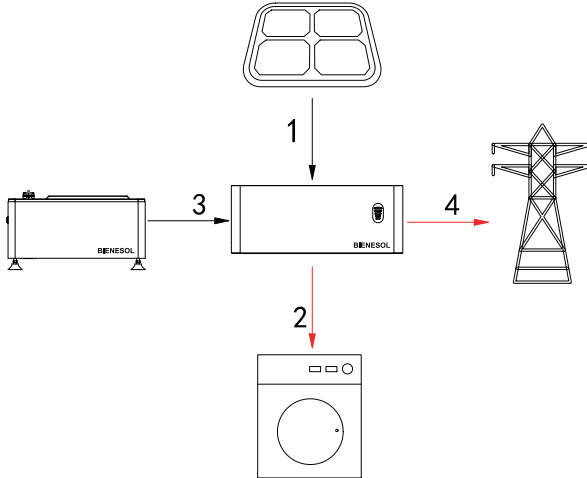

Charging State: Photovoltaic and grid power prioritize charging the battery at the set power level. When the battery reaches the set SOC, charging stops and the PV power is discharged to the grid. (This mode requires setting the discharge time period and power level.)

Discharging State: Inverter power prioritizes powering off-grid loads, with any excess power discharged to the grid (total power not exceeding the rated power).

Fault Codes and Troubleshooting

Code	Fault Information	Troubleshooting
1000	Inverter over voltage	The load output voltage is abnormal and this fault will disappear automatically; if the fault persists, please contact service engineer.
1010	Inverter over voltage	The load output voltage is abnormal and this fault will disappear automatically; if the fault persists, please contact service engineer.
1020	Inverter over current	The standby load is over current. You need to reduce the power consumption of the standby port. This fault will automatically disappear. If the fault persists, please contact service engineer.

1040	Inverter short circuit	The standby load circuit is short circuited. Check whether the standby port is short circuited. If the fault persists, please contact service engineer.
1050	Inverter overload alarm	The standby load exceeds the rated power. You need to reduce the power consumption of the standby port. The fault will automatically disappear. If the fault persists, please contact service engineer.
1060	Inverter overload protection	Solution is the same as "inverter overload alarm"
1070	Inverter fuse abnormality	The backup side fuse is abnormal. You need to disconnect the photovoltaic and grid connections, and then restart the system. If the fault persists, please contact service engineer.
1080	Inverter relay abnormality	The backup side replay is abnormal. You need to disconnect the photovoltaic and grid connection, and then restart the system. If the fault persists, please contact service engineer.
1160	Battery over voltage alarm	The battery voltage exceeds the maximum battery input voltage of the inverter. Check whether the battery voltage is within the rated range of the inverter. If the fault persists, please contact service engineer.
1170	Battery over voltage protection error	The battery voltage exceeds the maximum battery input voltage of the inverter. Check whether the battery voltage is within the rated range of the inverter. If the fault persists, please contact service engineer.
1180	Battery low voltage alarm	The battery voltage is lower than the minimum battery input voltage of the inverter. The battery needs to be charged. If the fault persists, please contact service engineer.
1190	Battery low voltage protection error	The battery voltage is lower than the minimum battery input voltage of the inverter. The battery needs to be charged. If the fault persists, please contact service engineer.
1200	Battery over current	The battery is over current. You need to reduce the power consumption. This fault will automatically disappear. If the fault persists, please contact service engineer.
1210	Battery management system (BMS) communication error	The battery and inverter are communicating abnormally. Try to wake up the battery. If the wake up fails, please contact service engineer.
1400	AC Grid over voltage	The AC power grid is abnormal. The fault will automatically disappear after the power grid returns to normal. If the fault persists, please contact service engineer.

1410	AC Grid under voltage	The AC power grid is abnormal. The fault will automatically disappear after the power grid returns to normal. If the fault persists, please contact service engineer.
1420	AC Grid under frequency	The AC power grid is abnormal. The fault will automatically disappear after the power grid returns to normal. If the fault persists, please contact service engineer.
1430	AC Grid short circuit	The AC power grid is abnormal. The fault will automatically disappear after the power grid returns to normal. If the fault persists, please contact service engineer.
1450	AC Grid overload alarm	The AC power grid is overloaded. You need to reduce the number of electrical devices. This fault will automatically disappear. If the fault persists, please contact service engineer.
1460	AC Grid overload protection	The AC power grid is overloaded. You need to reduce the number of electrical devices. This fault will automatically disappear. If the fault persists, please contact service engineer.
1470	AC Grid fuse error	The grid fuse is abnormal. Disconnect the photovoltaic and grid connections, and then restart the system. If the fault persists, please contact service engineer.
1480	AC Grid replay error	The grid relay is abnormal. Disconnect the photovoltaic and grid connections, and then restart the system. If the fault persists, please contact service engineer.
1560	PV1 over voltage protection error	Check the photovoltaic module voltage to ensure it is lower than the maximum DC input voltage of the inverter. If the fault persists, please contact service engineer.
1570	PV1 under voltage protection error	This warning usually appears in the morning or evening, which is normal. It will disappear automatically. If this warning appears during the day, check the photovoltaic module connection. If the fault persists, please contact service engineer.
1580	PV1 over current protection error	Check the photovoltaic module current to ensure it is lower than the maximum DC input current of the inverter. If the fault persists, please contact service engineer.
1590	PV1 reverse connection protection error	The photovoltaic is reversed, so the wiring of PV+ and PV- needs to be swapped.

1640	PV2 over voltage protection error	Solution is the same as "PV1 over voltage protection error"
1650	PV2 under voltage protection error	Solution is the same as "PV1 under voltage protection error"
1660	PV2 over current protection error	Solution is the same as "PV1 over current protection error"
1670	PV2 reverse connection protection error	Solution is the same as "PV1 reverse connection protection error"
1720	PV3 over voltage protection error	Solution is the same as "PV1 over voltage protection error"
1730	PV3 under voltage protection error	Solution is the same as "PV1 under voltage protection error"
1740	PV3 over current protection error	Solution is the same as "PV1 over current protection error"
1750	PV3 reverse connection protection error	Solution is the same as "PV1 reverse connection protection error"
1800	PV4 over voltage protection error	Solution is the same as "PV1 over voltage protection error"
1810	PV4 under voltage protection error	Solution is the same as "PV1 under voltage protection error"
1820	PV4 over current protection error	Solution is the same as "PV1 over current protection error"
1830	PV4 reverse connection protection error	Solution is the same as "PV1 reverse connection protection error"
1880	Radiator overheat alarm	Check the inverter installation and ensure that the inverter is well cooled. If the fault persists, please contact service engineer.

1890	Radiator overheat protection error	Check the inverter installation and ensure that the inverter is well cooled. If the fault persists, please contact service engineer.
1900	Radiator low temperature alarm	The temperature is lower than the minimum operating temperature of the inverter. Check the installation of the inverter. If the fault persists, please contact service engineer.
1910	Radiator low temperature protection error	The temperature is lower than the minimum operating temperature of the inverter. Check the installation of the inverter. If the fault persists, please contact service engineer.
1920	Radiator sensor disconnected	The temperature sensor is abnormal. If the fault persists, please contact service engineer.
1930	Internal overheat alarm	Check the inverter installation and ensure that the inverter is well cooled. If the fault persists, please contact service engineer.
1940	Internal overheat protection error	Check the inverter installation and ensure that the inverter is well cooled. If the fault persists, please contact service engineer.
1990	Internal protection fault	There is an internal fault in the device. Disconnect the AC power supply and restart the inverter. If the fault persists, please contact service engineer.
2050	Insulation failure	Check the insulation of the PV module to the ground, and ensure that the insulation resistance is greater than 200K Ω , ensure that the inverter ground connection is reliable; if the fault persists, please contact service engineer.
2060	Meter communication failure	The communication between the meter and the inverter is abnormal. Try to reconnect the meter and the inverter. If the connection fails, please contact service engineer.

Technical Parameters

PV hybrid inverter

Model	Cube-AIO-M
PV Input (PV)	
Recommended Module Power (Wp)	300 - 550
Quantity of PV Module	1 to 4
Max. PV Input Power (W)	2500
Startup Voltage @Rated condition (V)	22
Operating Voltage Range per Input (V)	16 - 60
Max. Input Voltage per Input (V)	60
Nominal Input Voltage (V)	42
Short Circuit Current per Input (A)	18
Max. Input Current per Input (A)	16
Quantity of MPPTs	4
AC Port (On-grid)	
Max. AC Output Power (VA)	2500
Nominal AC Output Current (A)	3.5
Max. AC Output Current (A)	11
Nominal AC Voltage (V)	220/230/240 L/N/PE
Nominal AC Frequency (Hz)	50/60
Power Factor	>0.99 default 0.8 leading -0.8 lagging
THDI	≤3%@100% Load
Nominal AC Output Power (W)	2500
AC Port (Off-grid)	
Max. AC Output Power (VA)	2500
Nominal AC Output Power (W)	2500
Nominal AC Output Current (A)	3.5
Max. AC Output Current (A)	11

Nominal AC Voltage (V)	220/230/240 L/N/PE
Nominal AC Frequency (Hz)	50/60
Switch Time [ms]	< 20
Efficiency	
Peak Inverter Efficiency	94.5%
MPPT Efficiency	99.9%
Battery Charge/Discharge Efficiency	94%/94%
No-load power consumption	< 25W
Shut-down and consume electricity	< 1W
Mechanical Data	
Dimensions (W×H×D mm)	485*325*180
Weight	17.5
General Data	
Communication	Wi-Fi/(Bluetooth)
Extra Communication Port	RS485
Display	SOC Light
Ingress Protection	IP65
Type of Isolation	Reinforced insulation
Cooling	Natural convection
Protection Class	I
Over-voltage Category	PV II AC III
Operating Ambient Temperature Range	-20 ~ +60 °C
Max. Operating Altitude [m]	2000
Relative Humidity	0-95%, Non condensing

Maintenance Guide

Routine Maintenance

- During normal operation, regularly check the environmental conditions and device status to ensure they remain normal. Ensure that the environmental conditions have not changed adversely, the device is not exposed to inclement weather, and is not covered by foreign object.
- If any problems are detected, do not use the device until the fault is corrected and normal conditions are restored.
- The device firmware version can be checked through the monitoring system.
- Avoid unscheduled repairs, use only genuine spare parts for all repairs.

Battery Pack Maintenance

- Battery maintenance must be performed by or under the supervision of personnel familiar with battery characteristics and related safety precautions.
- When replacing batteries, use only the same type and quantity of batteries.

General Instructions for Battery Disassembly and Assembly:

- Do not dispose of batteries in fire, as this may cause them to expose.
- Do not open or damage batteries. Leaked electrolyte can damage skin and eyes and may be highly toxic.
- Batteries pose a risk of electric shock and high short-circuit current. Observe the following precautions when handling batteries.
 - 1.Remove watches, rings, or other metal objects.
 - 2.Use tools with insulated handles.
 - 3.Wear rubber gloves and boots.
 - 4.Do not place metal parts or tools on the battery.
 - 5.Disconnect the charging power source before connecting or disconnecting the battery terminals.
 - 6.Check the battery for accidental grounding. If so, remove the grounding source.

Storage and Disposal

- If the device is not to be used immediately or needs to be stored for an extended period, please check that the packaging is intact. The device should be stored in a well ventilated room, and the environment should be protected from damage to the device components.
- During long-term storage, the product should be charged and discharged every 3 months. Products that have not been charged and discharged for more than 3 months will be void of warranty service.
- If the battery level of the product is extremely low and it has been unused for an extended period, it must be charged before use.
- After an extended period of inactivity, a comprehensive inspection should be performed before restarting the device.
- Upon device decommissioning, it must be properly disposed of in accordance with local regulations, as its components may pose a risk to the environment.
- If conditions permit, fully discharge the battery and place it in a designated battery recycling bin. Batteries containing potentially hazardous chemicals must not be disposed of as regular trash. Please comply with local laws and regulations regarding battery recycling and disposal.
- If a product malfunction prevents the battery from fully discharging, do not place it in a battery recycling bin. Contact a professional battery recycling company for disposal.
- Over-discharged batteries that can not be charged must be properly disposed of.

Warranty

Except as expressly provided in this warranty, BIENESOL provided no warranties, express or implied, whether oral or written.

Damage caused by the following circumstances is not covered by our warranty:

- Transportation damage
- Installation or commissioning by unauthorized dealers.
- Failure to comply with the user manual, repair regulations, and maintenance.
- Modification, alteration, or attempted repair by unauthorized dealers.
- Improper use
- Failure to comply with relevant safety regulations

• Force majeure

1. Our warranty does not cover cosmetic defects that do not directly affect energy output or impair the product's form, fit or functionality.
2. Claims outside the scope of our warranty (especially claims for direct or indirect damages, disassembly and installation costs, lost profits, etc.) are not covered by our warranty.
3. In no event shall BIENESOL be liable for personal injury or any other damages (including direct, indirect, incidental, or consequential damages) arising from the use of this system, even if BIENESOL has been advised of the possibility of such damages.

Dealer Responsibilities

If a device malfunctions or issues occur, the dealer is responsible for working directly with the BIENESOL service center to minimize returns for non-faulty devices. The BIENESOL service center will work with the dealer to resolve any malfunctions or fault notifications through telephone support or direct computer connection.

Note: To obtain further compensation or a replacement device, the dealer/installer must first contact BIENESOL and follow the instructions to fulfill their dealer/installer responsibilities. During the Data Transfer Unit (DTU) warranty period, service requests the invoice and purchase date, in addition, the product logo must be clearly visible; otherwise, warranty service will be void. For more information, please refer to the BIENESOL Warranty Policy.